

1	1
2	2
2.1	2
2.2	2
2.3	2
2.4	6
3	8
3.1	8
3.2	24
3.3	26
3.4	40
3.5	52
3.6	52
3.7	53
3.8	55
4	57
4.1	58
4.2	62
4.3	63
4.4	81
5	84
5.1	84
5.2	85
5.3	86
5.4	87
5.5	90

5.6	90
6	92
6.1	92
6.2	92
7	93
7.1	93
7.2	93
7.3	97
7.4	102
8.	103
9	104

1

2021 5

2021 5 8

2021 5 8 371202-2021-078-M

2021 3

2015 4

2024 5

2

2.1

1

2

3

4

2.2

1

2

3

4

2.3

2.3.1

1

2007 11 1

2 2015 1 1
3 2017 6 27

4
2018 10 26

5 2019 1 1
6 (2020 9 1)

7 2021
8 2021
9 2018.12.29

2.3.2

1 2005 1 26 79
2006 1 8

2 2014 119
3 2022
4 2021 15 2020 11 5
2021 1 1

5 2013 12 4 32
2013 12 7

6 2002 4 30
57 2002 5 12

7 2024 5
8 2009 130

9 2011 17

10

2015 4

11

2016	74				
	12			2021	
16	2020	11	5	2021	1 1
	13				HJ 941-2018
	14				
	15				HJ 589-2021
	16				DB 37/T 3599-2019
	17				
	18			(2014 15)
	19				2021 14
	20				
	21				
2016	141				
	22				2020 37
	23				2023 42
	24				
				2020	1 1
	25			(2016
37)				
	26				2024 5
	27				<
		>		2017	21
	28				
		2018	8		
	29				2022 6
2.3.3					
	1			GB18218-2018	
	2				GBZ 2.1-2007
	3				GBZ 2.2-2007

29

GB50406-2017

30

2

HG/T4335.2-2012

2.3.4

1

2016 12

2

2019 9

3

2020 12

4

2021

371212-2021-078-M

5

2.4

1

2

3

4

5

2.4-1

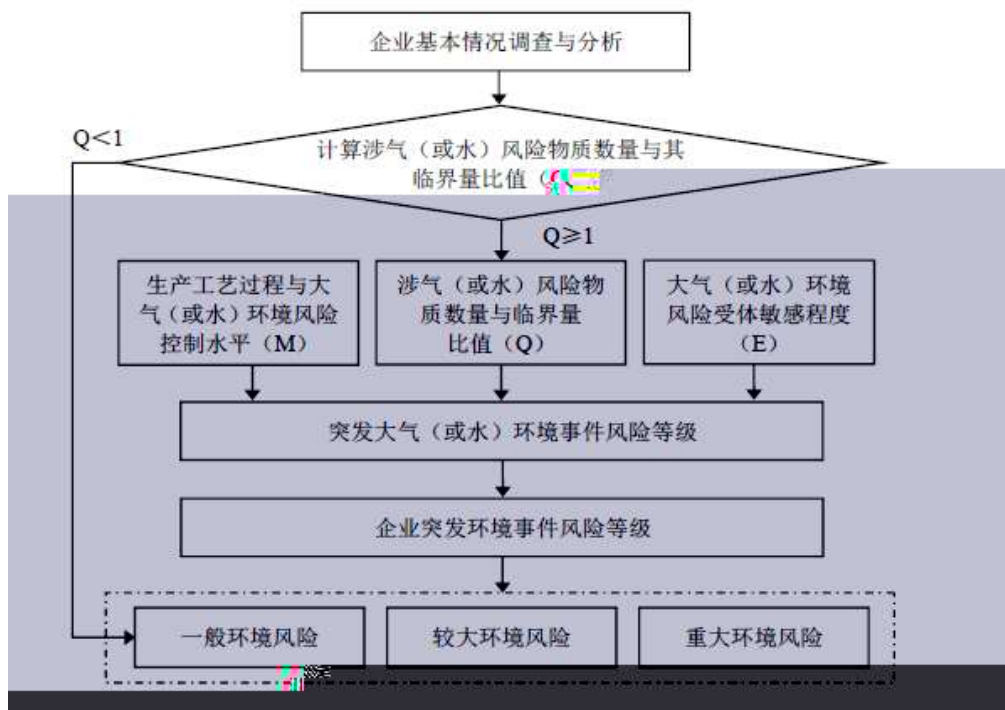

2.4-1

3

3.1

3.1.1

2 105m² 2 320m²
2 420m³ 1 1250m³ 2 1650m³
SO₂ NO_x
SO₂ NO_x 2
420m³ 1 1250m³ 2 105m² 2 320m²
2 1650m³
2016
130

3.1-1

			913712001695745282
			13561713679
			qingjin1999@163.com
	1964		
	1155		
	36°18'19.00"N 117°32'32.00"E		
	1155	365	24

3.1.2

1#-5#

TRT

1#-4#

2

3.1.3

3.1-2 1

		105m ²	×2	320 m ²	×2
		600m		200m	12 m ²
		800m ³	36	5	

3.1-3

			t/a
1		PB FB P +	5010916
2			627166.5
3		3~0mm	615576
4		25~0mm	313058
5		40mm	33013.6
6		/	818251.6
7			236099.5
8		20%	1155
1		10 ⁴ kWh/a	30208
2		10 ⁴ m ³ /t	111.6
3		10 ⁴ m ³ /a	3948
4		10 ⁴ GJ/a	26.28
5		10 ⁴ Nm ³ /a	1216.8
			t/a
1		5~150mm	6441373
			t/a
1			5786326
2		0 6~18mm	424876
3		/ 5~30mm	1050221
4		/	1773042
5		/	516525

	1		10 ⁴ kWh/a	10160.92
	2		10 ⁴ m ³ /t	224.63
	3		10 ⁴ m ³ /a	273876.48
	4		10 ⁴ m ³ /a	1172
	5		10 ⁴ t/a	259.56
	6		10 ⁴ Nm ³ /a	9142
	7	2%	10 ⁴ Nm ³ /a	22177
	8		10 ⁴ Nm ³ /a	14094
	1	+	t/a	4258890
	2		m ³	763016
	3		10 ⁴ kWh/a	1917

3.1-4

3.1-4

			105m ²	2
			140m ²	2
			G4-73.NO18D	4
			LK-22.5m	2
			LDA-10	1
			TDSS2690	2
			150- . -	1
			315×4157×3147mm	2
			130m ²	2
			113m ²	2
			75m ²	1
			320m ²	2
			320m ²	2
			Y3790/48K	14
			LK-22.5m	4
	16T		GD16/32-13.5A5	2
			LHBJ-V150×600	4
			4 - . - / . - -	2
			6 - - 4 - -	2
			130m ³	2
			113m ³	2
			75m ³	1
			220m ³	2
			1200x1000	4
			B650	8
			B800	24
			B1200	34

	PDx 32SDF1	32
	1000x7180x10	32
	400x2000mm	4
	400	4
	3800x14000mm	2
	4400x18000mm	2
	1282x4046mm	2
	3100x7800mm	2
	XB1640x2460	2
	XB1640x3100	2
	XB1640x2200	2
	900x700	2
	B650	15
	B1000	12
	B1200	2
	1000x5000x10	15
	J360	2
	3000x12000mm	1
	3000x12000mm	1
	1500x2740mm	2
	XBSFJ-1 185x500	1
	XBSFJ-1 185x520	1
	HYC-5500	1
	420m ³ ×2	2

		176×6000	9
		176×6000	5
		60m	2
		75m	2
			1250 1 3
			1650 1 3
			1650 1 3
			420 1 3
			420 1 3
		4800x3540x6972	3
		2420x1340	3
		800x600	3
		TZ3B-01-02	6
		6000x2400	3
		6mx8mx6m	3
		12mx8.5mx1.2m	2
		14mx8mx4m	1
		9mx16mx6m	3
		1m ³	3
		11m ³	2
		100m ³	1
		2.87m ³	1
		20m ³	2
		1.38m ³	13
		3m ³	4
		13m ³	1
		1.5m ³	2
		0.5m ³	1
		10m ³	3
		5.09m ³	2
		6m ³	1
		3.4m ³	2
		50m ³	1
		18m ³	1
		KQSN600-M9/751	8
		XBC5.9/410-400N9/486	4
		KQSN350-M6/654	8
		XBC6.0/210-300M9/445	4
		KQSN150/460-75/4	12
		XBC8.0/55-W150*25*4	4
		KQSN300 N9/445	8
		KQSN150-M9/206 T	12
		KQSN300-M9/387 T	12
		KQSN250-M9/327	8
		KQSN300-M13/313	12
		LF-47(B) :7.35	8

		×104m ³ /h		
		DN300	5#	2
		DN450	5#	2
		JHGXY-3600	5#	2
		ZP9x3	5#	12
		LF50S	5#	2
		3600	4#	2
		STDN450	4#	2
		STDN300	4#	1
		GSL-3.0	1#	1

7

600

59.89%

20.34%

19.77%

7

14

14

25 °

401s

3-4g

3z

401s

3z

jZ

cM

Art

>10000m

2

IV

V

I

II

III

IV

V

3

4

0.10g

4

1

5~15m

1000~3000m³/d

500m³/d

1000m³/d

1~5m

1~3m

0.11 0.73g/l

HCO₃-Ca

100m³/d

100m³/d
0.25~0.85g/l
HCO₃ SO₄-Ca
SO₄ HCO₃-Ca

500m³/d 500~1000m³/d
1000~5000m³/d
HCO₃-Ca Mg 0.5~0.8g/l

2

3

4

1

2~7m

3~5m

2

7-9

5-6

5

18

395 98%

2%

395 5km 70

59km

50km² 100km² 8 100km² 1000km²

4 1000km² 1

5 20

80

613 2.08 m³

65.5km

1214km² /

100 500m

3 9 26 118

450 200

180

40 93

30

284

17.40

13.27 76.3%

3 17.27% 1.12

6.42% 4.84 0.0704

3.1.5

3.1-5

3.1-5

	GB3095-2012	
	(GB3838-2002)	
	GB/T14848-2017	
	(GB3096-2008)	3

	GB36600-2018	
--	--------------	--

3.1.6

1

3.1-6 2023

		³ CO mg/m ³			³	
SO ₂		9	9	11	60	
NO ₂		36	41	34	40	
PM ₁₀		75	76	74	70	
PM _{2.5}		41	42	40	35	
CO	8	1.3	1.5	1.5	4	
O ₃		179	182	193	160	

PM₁₀ PM_{2.5} O₃ 8
GB3095-2012

2

2023

(GB 3838-2002)

2023

2023

2023

3

3

GB/T 14848-2017

3

(GB 3096-2008)2

4

GB36600-2018

3.2

3

3.2.1

HJ 941-2018

5

4

5km

77367

3.2-1

22		2652	NW	967		0531-76620422
23		2707	W	1407		0531-76511319
24		2763	NE	2084		0531-

64		4676	SW	530		0531-76608238
65		5007	SW	1199		0531-76511243
66		5190	S	586		0531-78612088
67		5276	S	317		0531-76611233
68		5937	E	560		0531-76755099

3.2.2

1

2

GB/T 14848-2017

3.2-2

			m
1		S	360
1			20km ²

3.3

2022

GB12268-2012

GB18218-2018

HJ941-2018

3.3-1

3.3-1

		A	34		
3		A	180	1336-21-6	10
4		A	183	7664-93-9	10
5		A	310	7775-09-9	100

98%			58m ³	33.97	33.29
			58m ³	81.2	81.2
			/	0.3	0.3
			/	0.1	0.1
			/	48.2	48.2

				blast furnace gas
				30
				:CO, CO ₂ , N ₂ H ₂ CH ₄
		CO	25%	900 2000
	(kJ/mol)	3344~4180	(MPa)	77.9N/cm ²
	%(V/V)	40%	%(V/V)	4.5%
			()	700
				18%
				LD50
	UN			1023

				Coke Oven Gas
				30
		C2	900	2000
	(kJ/mol)	16720 18810	(MPa)	77.9N/cm ²
	%(V/V)	40%	%(V/V)	4.5%
			()	600~650
				18%
				LD50
	UN			1023

	CAS 1336-21-6	UN 2672	82503
			Mpa
			/
	=1	0.91	

		sulfuric acid	
	H ₂ SO ₄	98.08	UN 1830
	/ / 1A / 1	81007	CAS 7664-93-9
	10.5	:330.0	
	1 1.83	1 3.4	
	kPa 0.13(145.8)	kJ/mol	
		MPa	
	%	% 10.4	
		mJ	
	MPa		
		CO CO ₂	
	LD ₅₀ 2140mg/kg() LD ₅₀ 510mg/m ³ 2 ()		
	LD ₅₀ 320mg/m ³ 2 ()		

15

15

--	--

		Mpa	
		/	
=1	1		

3.3.1

A

NH3-N

/----j d,I

COD Cr

.-----j d,I

A

3.3-5

3.3-5

			CAS	
1	A	34	/	7.5
2	A	34	/	7.5
3	A	180	1336-21-6	10
4	A	183	7664-93-9	10
5	A	53	74-98-6	10
6	A	52	74-86-2	10
7	A	392	/	2500

3.3-6

		t	t		Q	Q
		4.89	10		0.489	43.54
		0.2	10		0.02	
		396.4	10		39.64	
		33.29	10		3.329	
		0.3	10		0.03	
		0.1	10		0.01	
		48.2	2500		0.019	

Q 43.54 10 N 100 Q2

3.3.2

A

A

3.3-7

3.3-7

		t	t		Q	Q
		396.4	10		39.64	43.8
		33.29	10		3.329	
		81.2	100		0.812	
		48.2	2500		0.019	

Q 43.8 10 N 100 Q2

3.4

A.

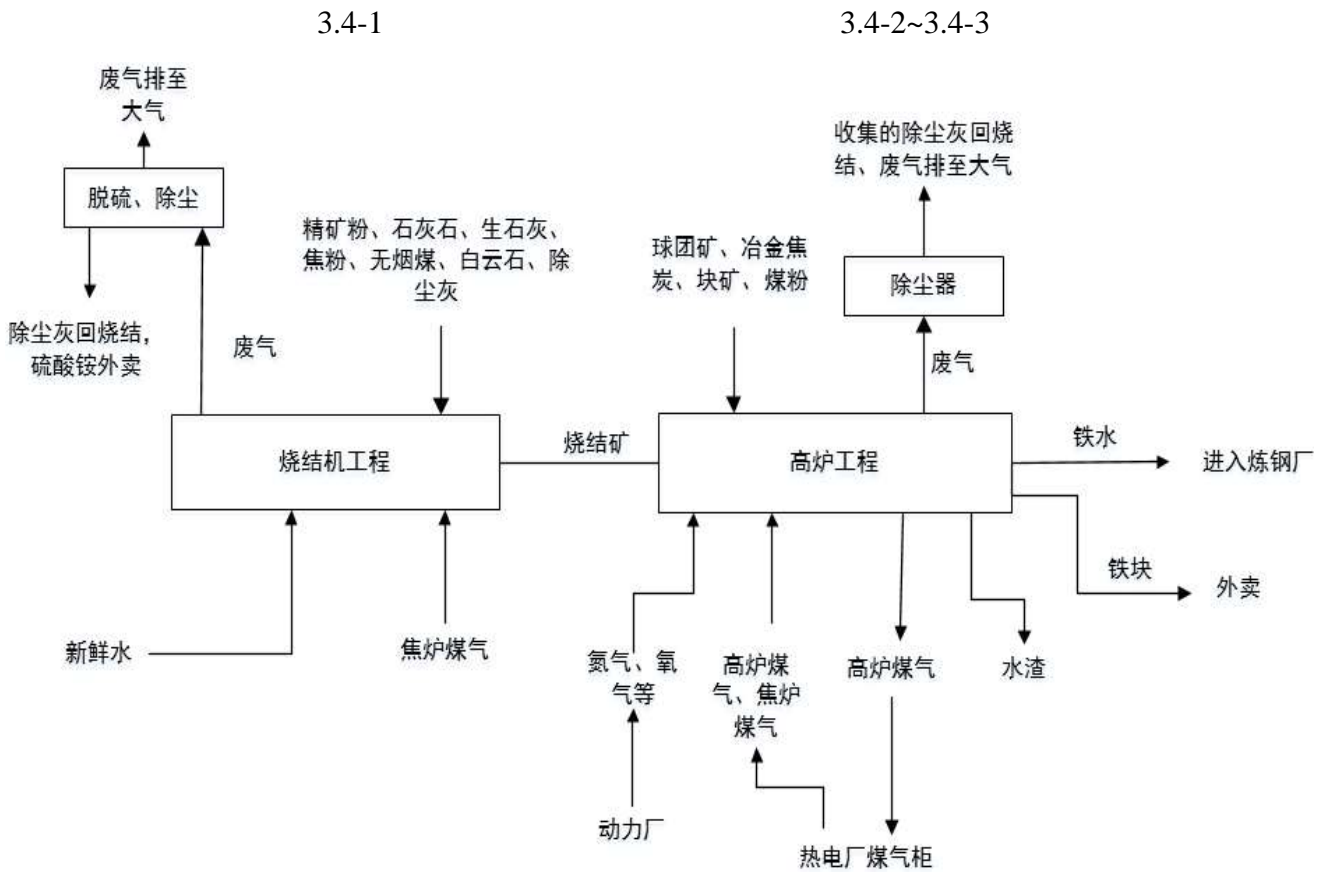

3.4-1

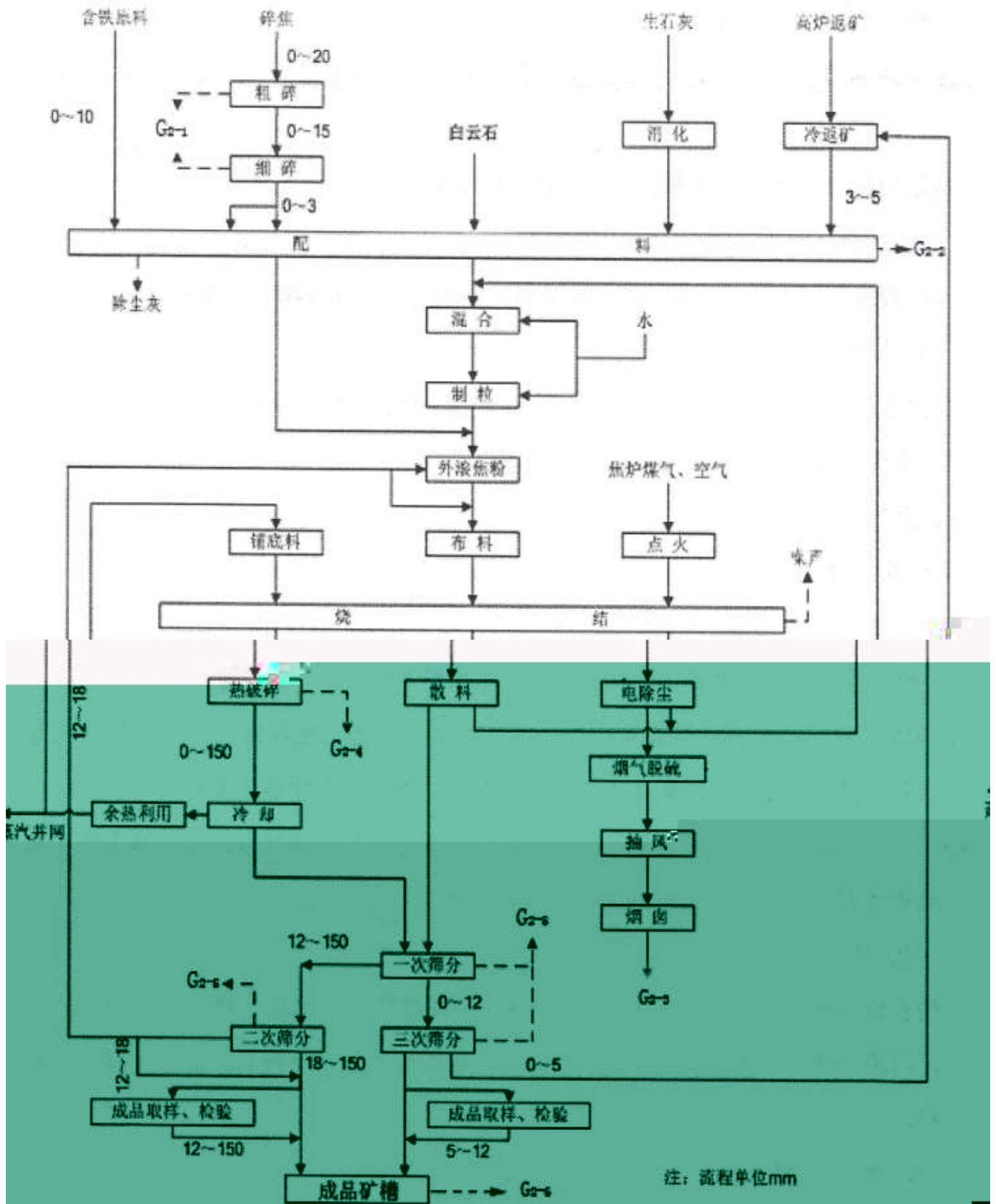

3.4-2

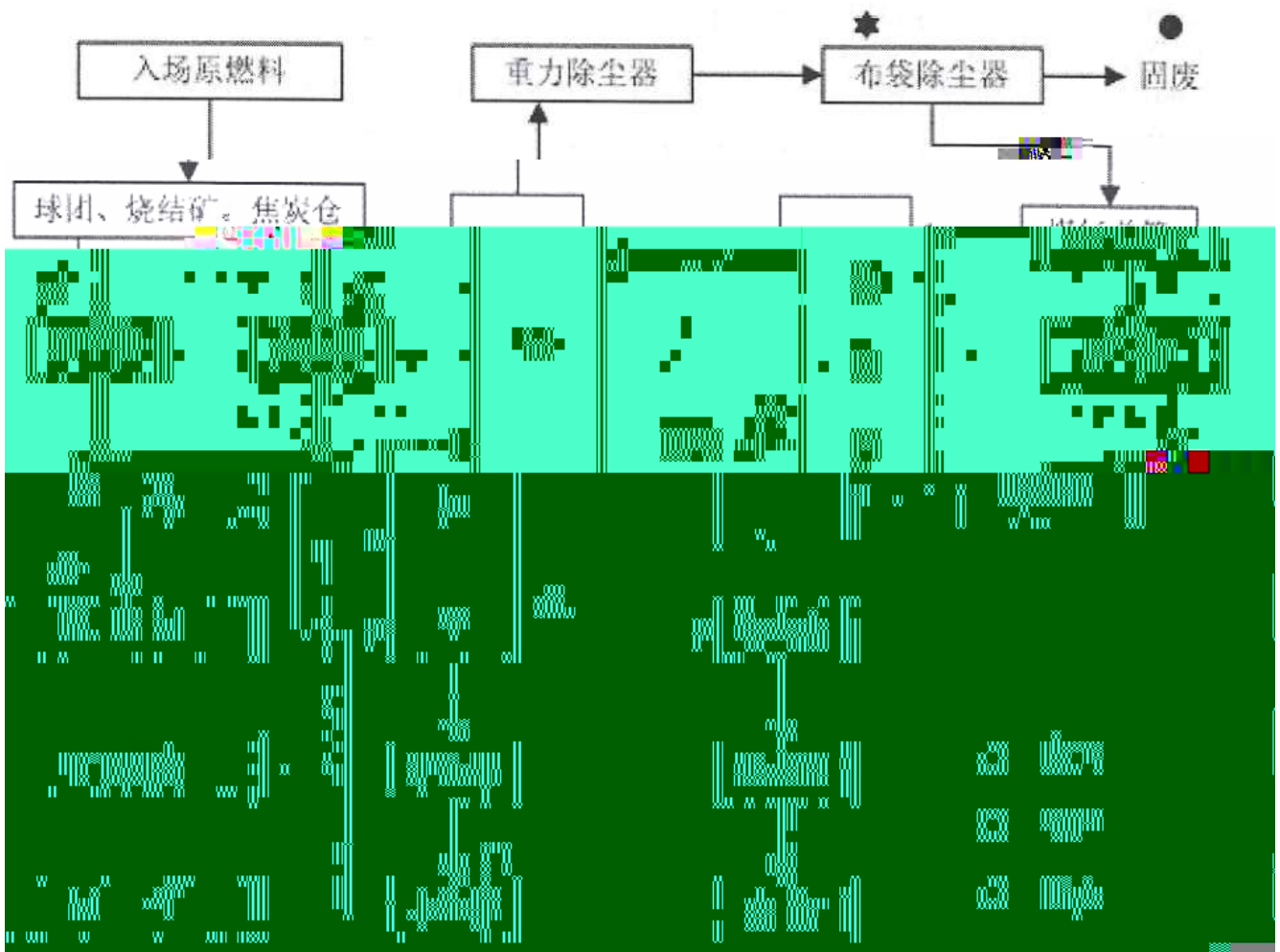

3.4-3

1

(1)

(<3mm)

2

(2)

16

2500

(3)

1

3800 14000mm

(4)

1 4400 18000mm

(5)

10~20mm

30~50mm

150mm

150

(6)

3

2

>5mm
>10mm
10 20mm
5mm
5 10mm
>20mm

(7)

(8)

0.8MPa, 170 °C 1
~35t/h

(9)

3# 4# +CFB + +SCR
+ +

0.5ng-TEQ/m³

(1)

(2)

2
30min 10min
20min
20min
140t
(3)
3
180
19 1250
3 2 1 1) 1

(4)

(5)

1.2-4.0mm

1

7m

(6)

4

1

1

6~10g/m³

(7)

3.4-4

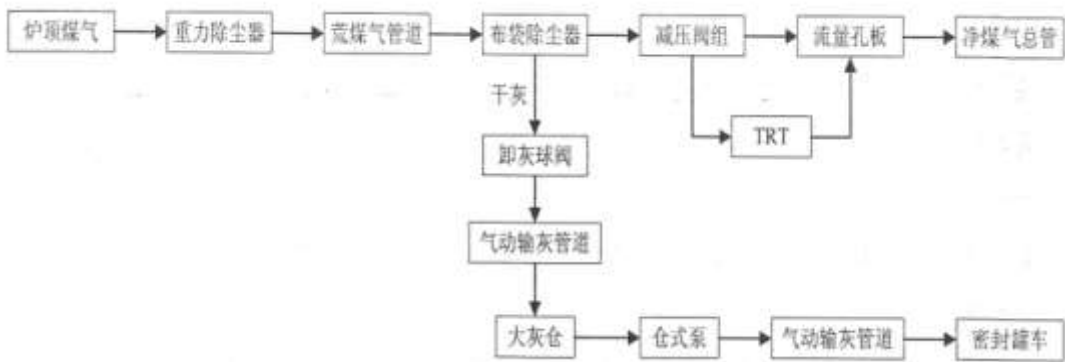

3.4-4

90~260 °C

260 °C

90 °C

TRT

TRT)

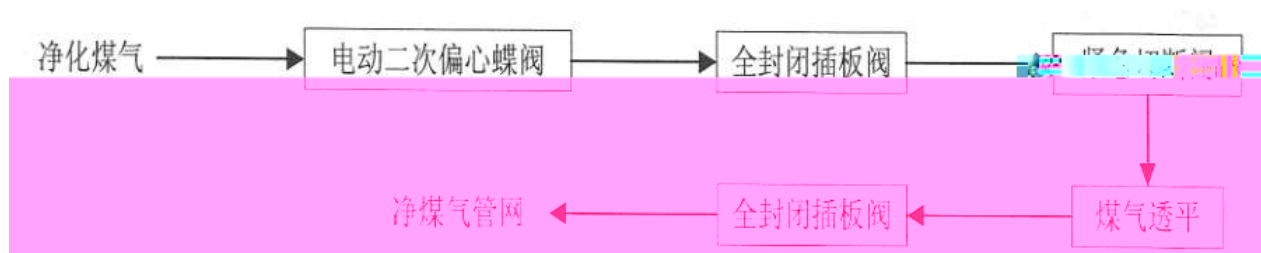

3.4-5 TRT

8

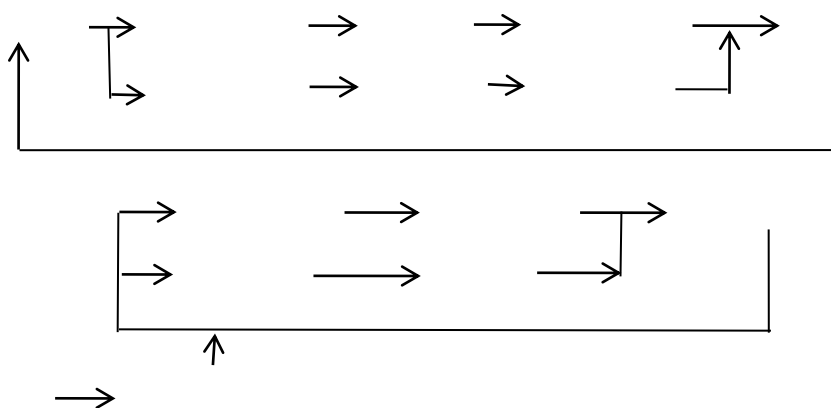

3.4-6

B.

3.4-1

					/
DA018	4#		SO ₂ NO _x	+CFB + +SCR +75m	
DA118	3#		SO ₂ NO _x	+CFB + +SCR +125m	
DA065	3#		SO ₂ NO _x	+	
DA066	4#		SO ₂ NO _x	+ +80m	
DA067	5#		SO ₂ NO _x	+ +80m	
DA013	3#4#			+32m	
DA016	3#			+28.5m	
DA020	4#			+38m	
DA012	3#4#			+20m	
DA091	3#4#			+18m	
DA086				+15m	
DA048	4#			+30m	

DA031	5#			+30m
DA001				+30m
DA002	YZ-6			+30m
DA087	3#4#			+15m
DA074	22#			+27m
DA085	23#			+21m
DA084	20#			+21m
DA004	15#			+20m
DA005	25#			+19m
DA006	26#			+19m
DA072	9#			+30m
DA073	18#			+24m
DA096				+25m
DA094	C			+25m
DA024	2#			+28m
DA069	3#			+28m
DA070	4#			+28m
DA025				+24m
DA095	E			+25m
DA017				+30m
DA059	4#			+35m
DA043	4#			+32m
DA088	4#			+30m
DA060	5#			+32.8m
DA046	5#			+31.7m
DA056	5#			+30m
DA029	1#			+28m
DA030	2#3#			+23m
DA015	3#			+45m
DA019	4#			+45m
DA087				+24m
DA093	B			+21m
DA023	1#		SO ₂ NO _x	+21m
DA010	1#2#			+23m

	DA008	1#2#			SO ₂ NO _x	+ +125m
	DA009	1#				+21m
	DA011	2#				+39m
	DA090	1#				+15m
	DA007	1#				+25m
	DA022	1#				+30m
	DA021	1#				+30m
	DA028	2#			SO ₂ NO _x	+55m
	DA027	2#3#				+24m
	DA026	2#				+26m
	DA065	3#			SO ₂ NO _x	+55m
	DA039	3#				+27m
	W1				SS	
	W2				COD BOD ₅ SS	
					t	
					298551.67	
					1305116.68	
					4727.56	
					5.02	
					39294.76	

					5.304	
					/	
	N				(dB)A	

3.5

1

2

3

24

4

5

6

3.6

2022

3.6-1

3.6-1

			t	t	
			4.89	20	
			0.2	20	
			17.55	200	
			0.3	50	
			0.1	50	

3.7**3.7.1**

10^{-7} cm/s

3# 4#

0.64m^3

4.6m^3

27m^3

1 1000m^3

1#-3#

4# 5#

1 1000m^3

4# 5#

3.7.2

1

2

3

4

5

3.7.3

3.8

3.8.1

12

3.8.2

3.8-1

3.8-2

3.8-1

	24		0531-75819518	
				13561708577
				18263463698
				15515060692
				18062945667
				13837218278
				13641857785
				13506343316
				18763451749
				13561702997
				13863447397
				15866340126
				13863406584
				13806342099
				13963401829
				15863400882
				14763413462
				14706341518
				18763439192
				15166341778
				15763465978
				13863429498

				15163424203
				13863437319
				13561741267
				13963425440
				13455893444
				13563480462
				18763479623
				15163429192
				13646347826
				13863419772
				15263408528
				13963473928
				18763420899
				13963463628
				15133641539
				13561705829
				13666345744
				13563408068
				13563447156
				13963421552
				13863428388
				13906347140
				13561738442
				13969373438
				13963419172
				13863488087
				13455493893
				13563487058
				13506343316
				13963477486
				18363450128
				13561729024
				18266345458
				15106341925
				13516346644
				13561703537
				13506341874
				15263460590
				15763462615
				13468251106

				15863406951
				13863463644
				13563412349
				13963447912
				15020880403
				15166348309
				18766342202
			/	15064186667
			/	18663425138

3.8-3

			/	
1				119
2				120
3				122
4				110
5				0531-76213264
6				0531-76279088
6				0531-51707053
7				0531-51708400
8				0531-51708600
9				0531-76114187
10				0531-77996969 0531-77996966
11				0531-76210783
12			0531-76521651	
10				13863449121
11				0531-75819931
12				19863482030
13				0531-76260279
	0533-2827073 0531-76556800 76556877 0532-83889090 010-63131122 12369			

4

4.1

. - .5

2008 10 18 14 30
14 4 10

DN1200

12.24

2008 12 24 9 2
44 17 27
4 610
109 54 68Kpa 24

45%--60%

. .5

2010 1 18 8 30 6

2 440³

6

11 22 2

1 6 15 30

2

(1

1 16 17 56

2

(2

(

2

1 2

1

(

2 2

1 2

2

3 2

2

(

4

5

2003 1 13 5 5

2#

4#

30m 600mm

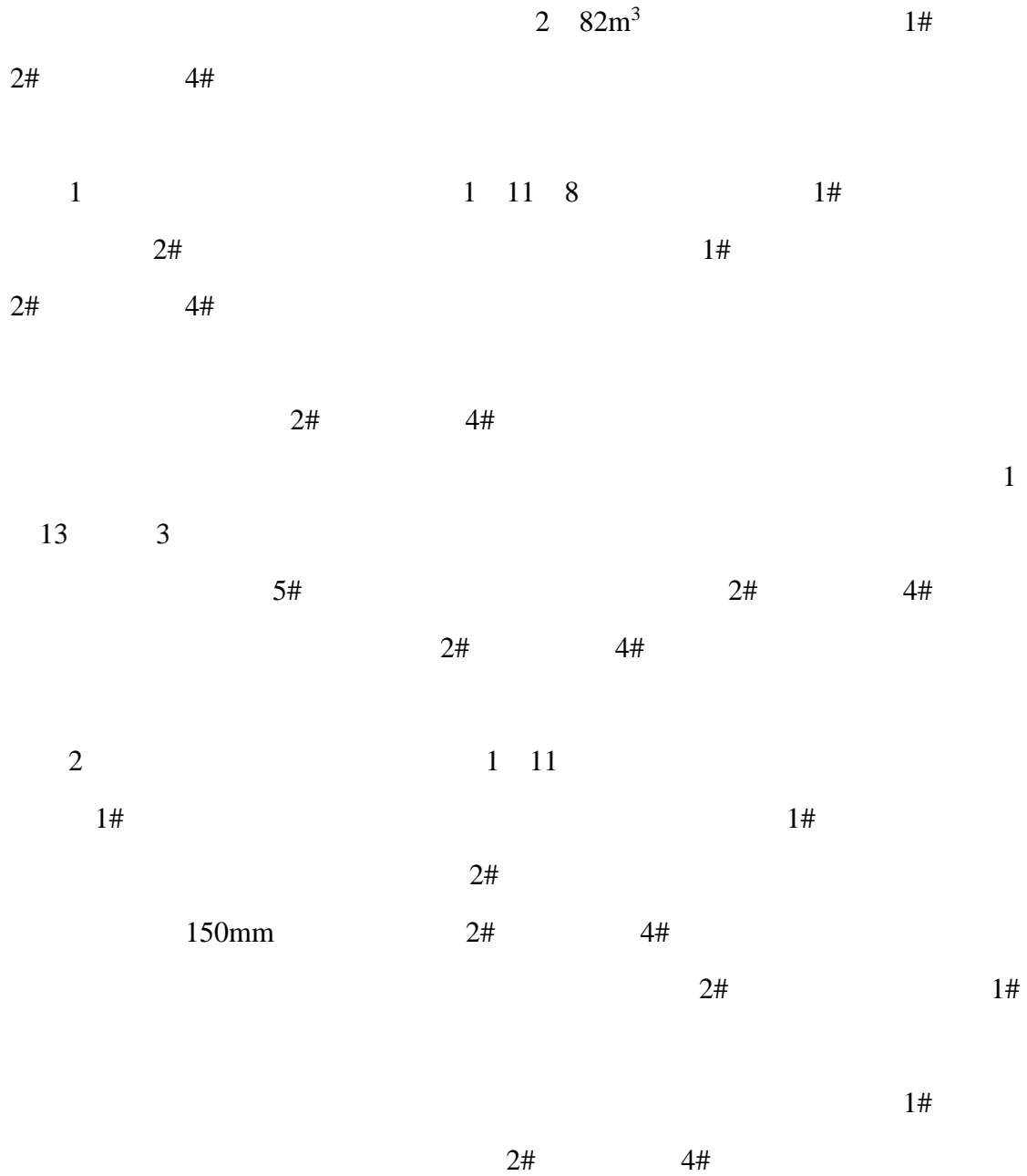

1

2

3

4

1

2013 3 1 15 20

2

1

2.6

7

2

1210

2

1

2005 10 15

18 10

19 10

2005 10 18 19

50%

4.2

4.2-1

4.2-1

1		35.1
2		18.2
3		15.6
4		12.4
5		8.2

35.1%

4.2-2

4.2-2

			CO H ₂ CH ₄		
			CO C ₃ H ₈		
			NH ₃		
			/		
		/	/	/	/
		/	/	/	/

4.3

4.3.1

<

>

$$V = V_1 + V_2 - V_3 + V_4 + V_5$$

V₁ m³

V₂

3 m³

V_3 m^3
 V_4 m^3
 V_5 m^3

$300m^3$ $V_1=300m^3$

GB50414-2018

GB50974-2014

20L/s

3h

$V_2=216m^3/$

$V_3=0$

$281m^3$

$V = 300+216+281=797m^3$

2#

1 $1000m^3$

1 $1000m^3$

$2000m^3$

4.3.2

(HJ169-2018)

E

10

4.3-1

/ / /	10mm	$1.00 \times 10^{-4}/a$
/	10min	$5.00 \times 10^{-6}/a$
		$5.00 \times 10^{-6}/a$

	10mm 10min	1.00×10 ⁻⁴ /a 5.00×10 ⁻⁶ /a 5.00×10 ⁻⁶ /a
	10mm 10min	1.00×10 ⁻⁴ /a 1.25×10 ⁻⁸ /a 1.25×10 ⁻⁸ /a
		1.00×10 ⁻⁸ /a
4 j j	10%	5.00×10 ⁻⁶ / m a 1.00×10 ⁻⁶ / m a
75mm . -j j	10%	2.00×10 ⁻⁶ / m a 3.00×10 ⁻⁷ / m a
150mm	10% 50 mm	2.40×10 ⁻⁶ / m a 1.00×10 ⁻⁷ / m a
	10% 50 mm	5.00×10 ⁻⁴ /a 1.00×10 ⁻⁴ /a
	10% 50mm	3.00×10 ⁻⁷ /h 3.00×10 ⁻⁸ /h
	10% 50mm	4.00×10 ⁻⁵ /h 4.00×10 ⁻⁶ /h

4.3-2

		10%	2.40×10 ⁻⁶ / m a
			1.00×10 ⁻⁶ / m a

4.3.3

4.3-3

		m³	t	kPa	CO %
	0.45kg/Nm ³	220	0.2	104	7.4
	1.3kg/Nm ³	72	4.89	104	20.5

4.3.2.1

HJ169-2018 F

$$Q_G = Y C_D A P \sqrt{\frac{M \gamma}{R T_G} \left(\frac{2}{\gamma + 1} \right)^{\frac{\gamma + 1}{\gamma - 1}}}$$

Q_G kg/s

P pa

C_d 1.0

M 0.028kg/mol

R 8.314J/ mol K

T_G 333K

A m²

Y

Cp

Cv 1.4

4.3-4

	kPa	m²	kg/s	CO kg/s	min	CO t
	104	0.00385	4.027	0.298	10	0.1788
	104	0.05307	20.05	4.110	10	2.466

10min

4.110kg/s

4.3.2.2

F 1.5m/s 25 50%

2018

1.94m/s 14.62 50% D 53.36%

HJ169-2018 H.1

4.3-5

	-1	-2
CO	380mg/m ³	95mg/m ³

1

CO 4.3-6

4.3-6

CO

	(m)	(min)	(mg/m ³)
1	10	0.11	4.16E-11
2	60	0.67	4.60E+03
3	110	1.22	8.57E+03
4	160	1.78	7.88E+03
5	210	2.33	6.43E+03
6	260	2.89	5.17E+03
7	310	3.44	4.20E+03
8	360	4.00	3.46E+03
9	410	4.56	2.90E+03
10	460	5.11	2.46E+03
11	510	5.67	2.12E+03
12	560	6.22	1.84E+03
13	610	6.78	1.62E+03
14	660	7.33	1.44E+03
15	710	7.89	1.28E+03
16	760	8.44	1.15E+03
17	810	9.00	1.04E+03
18	860	9.56	9.48E+02
19	910	13.11	8.67E+02
20	960	13.67	7.96E+02
21	1010	14.22	7.33E+02
22	1060	15.78	6.78E+02
23	1110	16.33	6.30E+02
24	1160	16.89	5.86E+02
25	1210	17.44	5.48E+02
26	1260	18.00	5.13E+02

27	1310	18.56	4.81E+02
28	1360	19.11	4.53E+02
29	1410	19.67	4.24E+02
30	1460	21.22	4.05E+02
31	1510	21.78	3.88E+02
32	1560	22.33	3.71E+02
33	1610	22.89	3.56E+02
34	1660	23.44	3.42E+02
35	1710	24.00	3.29E+02
36	1760	24.56	3.17E+02
37	1810	25.11	3.06E+02
38	1860	25.67	2.95E+02
39	1910	26.22	2.85E+02
40	1960	26.78	2.75E+02
41	2010	27.33	2.66E+02
42	2060	27.89	2.58E+02
43	2110	28.44	2.49E+02
44	2160	29.00	2.42E+02
45	2210	29.56	2.35E+02
46	2260	30.11	2.28E+02
47	2310	30.67	2.21E+02
48	2360	31.22	2.15E+02
49	2410	31.78	2.09E+02
50	2460	32.33	2.03E+02
51	2510	32.89	1.98E+02
52	2560	33.44	1.93E+02
53	2610	34.00	1.88E+02
54	2660	34.56	1.83E+02
55	2710	35.11	1.78E+02
56	2760	35.67	1.74E+02
57	2810	36.22	1.70E+02
58	2860	36.78	1.66E+02
59	2910	37.33	1.62E+02
60	2960	37.89	1.58E+02
61	3010	38.44	1.54E+02
62	3060	39.00	1.51E+02
63	3110	39.56	1.47E+02
64	3160	40.11	1.44E+02
65	3210	40.67	1.41E+02
66	3260	41.22	1.38E+02
67	3310	41.78	1.35E+02
68	3360	42.33	1.32E+02
69	3410	42.89	1.29E+02
70	3460	43.44	1.26E+02
71	3510	44.00	1.24E+02
72	3560	44.56	1.21E+02
73	3610	45.11	1.19E+02

74	3660	45.67	1.16E+02
75	3710	46.22	1.14E+02
76	3760	46.78	1.12E+02
77	3810	47.33	1.10E+02
78	3860	47.89	1.07E+02
79	3910	48.44	1.05E+02
80	3960	49.00	1.03E+02
81	4010	49.56	1.01E+02
82	4060	50.11	9.94E+01
83	4110	50.67	9.75E+01
84	4160	51.22	9.57E+01
85	4210	51.78	9.39E+01
86	4260	52.33	9.22E+01
87	4310	52.89	9.05E+01
88	4360	53.45	8.88E+01
89	4410	54.00	8.72E+01
90	4460	54.56	8.56E+01
91	4510	55.11	8.41E+01
92	4560	55.67	8.26E+01
93	4610	56.22	8.12E+01
94	4660	56.78	7.97E+01
95	4710	57.33	7.84E+01
96	4760	57.89	7.70E+01
97	4810	58.45	7.57E+01
98	4860	59.00	7.44E+01
99	4910	59.56	7.31E+01
100	4960	60.11	7.19E+01
	/(mg/m ³)	/m	/min
-1	380	1510	21.78
-2	95	4160	51.22

CO

-1 380mg/m³

1510m

21.78min CO

-2 95mg/m³

4160m

51.22min

2

CO

4.3-7

CO

	(m)	(min)	(mg/m ³)
1	10	0.09	7.45E-03
2	60	0.52	5.92E+03
3	110	0.95	4.43E+03
4	160	1.37	2.88E+03

5	210	1.80	1.97E+03
6	260	2.23	1.43E+03
7	310	2.66	1.08E+03
8	360	3.09	8.51E+02
9	410	3.52	6.87E+02
10	460	3.95	5.68E+02
11	510	4.38	4.78E+02
12	560	4.81	4.08E+02
13	610	5.24	3.54E+02
14	660	5.67	3.09E+02
15	710	6.10	2.73E+02
16	760	6.53	2.43E+02
17	810	6.96	2.18E+02
18	860	7.39	1.97E+02
19	910	7.82	1.79E+02
20	960	8.25	1.63E+02
21	1010	8.68	1.49E+02
22	1060	9.11	1.37E+02
23	1110	9.54	1.26E+02
24	1160	9.97	1.18E+02
25	1210	15.40	1.11E+02
26	1260	15.83	1.05E+02
27	1310	16.25	9.89E+01
28	1360	16.68	9.35E+01
29	1410	17.11	8.87E+01
30	1460	17.54	8.42E+01
31	1510	17.97	8.01E+01
32	1560	18.40	7.63E+01
33	1610	18.83	7.27E+01
34	1660	19.26	6.94E+01
35	1710	19.69	6.64E+01
36	1760	20.12	6.35E+01
37	1810	20.55	6.09E+01
38	1860	20.98	5.83E+01
39	1910	21.41	5.60E+01
40	1960	21.84	5.38E+01
41	2010	22.27	5.17E+01
42	2060	22.70	4.97E+01
43	2110	23.13	4.78E+01
44	2160	23.56	4.60E+01
45	2210	23.99	4.44E+01
46	2260	24.42	4.28E+01
47	2310	24.85	4.12E+01
48	2360	25.28	3.98E+01
49	2410	25.70	3.84E+01
50	2460	26.13	3.71E+01
51	2510	26.56	3.59E+01

52	2560	26.99	3.47E+01
53	2610	27.42	3.35E+01
54	2660	27.85	3.25E+01
55	2710	28.28	3.14E+01
56	2760	28.71	3.04E+01
57	2810	29.14	2.95E+01
58	2860	29.57	2.86E+01
59	2910	30.00	2.77E+01
60	2960	30.43	2.68E+01
61	3010	30.86	2.60E+01
62	3060	31.29	2.53E+01
63	3110	31.72	2.45E+01
64	3160	32.15	2.38E+01
65	3210	32.58	2.31E+01
66	3260	33.01	2.25E+01
67	3310	33.44	2.18E+01
68	3360	33.87	2.12E+01
69	3410	34.30	2.06E+01
70	3460	34.73	2.01E+01
71	3510	35.16	1.95E+01
72	3560	35.58	1.90E+01
73	3610	36.01	1.85E+01
74	3660	36.44	1.80E+01
75	3710	36.87	1.76E+01
76	3760	37.30	1.71E+01
77	3810	37.73	1.67E+01
78	3860	38.16	1.62E+01
79	3910	38.59	1.58E+01
80	3960	39.02	1.54E+01
81	4010	39.45	1.51E+01
82	4060	39.88	1.47E+01
83	4110	40.31	1.43E+01
84	4160	40.74	1.40E+01
85	4210	41.17	1.37E+01
86	4260	41.60	1.33E+01
87	4310	42.03	1.30E+01
88	4360	42.46	1.27E+01
89	4410	42.89	1.24E+01
90	4460	43.32	1.21E+01
91	4510	43.75	1.19E+01
92	4560	44.18	1.16E+01
93	4610	44.61	1.13E+01
94	4660	45.03	1.11E+01
95	4710	45.46	1.09E+01
96	4760	45.89	1.06E+01
97	4810	46.32	1.04E+01
98	4860	46.75	1.02E+01

99	4910	47.18	9.95E+00
100	4960	47.61	9.74E+00
	/(mg/m ³)	/m	/min
-1	380	655	5.67
-2	95	1310	16.25

CO

-1 380mg/m³ 655m 5.67min CO
 -2 95mg/m³ 1310m 16.25min

4.3.4

1

100%

HJ169-2018 A

$$Q_L = C_d A \rho \sqrt{\frac{2(P - P_0)}{\rho} + 2gh}$$

Q_L kg/s

C_d

A m²

P Pa

P₀ Pa

g

h m

4.3-8

Q _L		kg/s	2.47
C _d			0.62
A		m ²	0.0004906
P		Pa	101325
P ₀		Pa	101325
G		m/s ²	9.81

678	AS	678	AS
h		m	4
		kg/m ³	920.4

15min

15min

2.22t

HJ169-2018

A

$$Q_3 = a \times p \times M / (R \times T_0) \times u^{(2-n)/(2+n)} \times r^{(4+n)/(2+n)}$$

Q₃ kg/s

a 4.685 × 10⁻³ n 0.25

p Pa 25

R J/mol k 8.31

T₀ k 303k

u m/s 2.0m/s

r m

Rd> `

RiskSystem

105m²

4.3-10

4.3-10

4.3-10

	A/B		D			F		
	U=1m/s	U=2m/s	U=1m/s	U=1.94m/s	U=2m/s	U=1m/s	U=1.5m/s	U=2m/s
kg/s	0.0446	0.0787	0.0397	0.0664	0.0680	0.0398	0.0537	0.0664

1

4.3-11

4.3-11

	-1	-2
NH ₃	770mg/m ³	110mg/m ³

2

(A)

F

1.5m/s

25

50%

2018

1.94m/s

14.62

50%

D 53.36%

HJ169-2018

H.1

1

序号	风向	风速[m/s]	稳定性	测量的有效高度[m]	测筒口风速[m/s]	持续时间[min]	最大落地浓度[ug/m ³]	出现距离[m]	大气毒性终点浓度-1[m]	大气毒性终点浓度-2[m]
1	N	1.5	F		1	75178085044090848	16,021.9520	7.5	48.0	53.4
2	N	1.5	F		3	75178085044090848	16,021.9520	7.5	74.2	143.3
3	N	1.5	F		5	75178085044090848	16,021.9520	7.5	74.2	223.7
4	N	1.5	F		7	75178085044090848	16,021.9520	7.5	74.2	288.6
5	N	1.5	F		9	75178085044090848	16,021.9520	7.5	74.2	299.7
6	N	1.5	F		11	75178085044090848	16,021.9520	7.5	74.2	299.7
7	N	1.5	F		13	75178085044090848	16,021.9520	7.5	74.2	299.7
8	N	1.5	F		15	75178085044090848	16,021.9520	7.5	74.2	299.7
9	N	1.5	F		17	75178085044090848	16,021.9520	7.5	74.2	299.7
10	N	1.5	F		19	75178085044090848	16,021.9520	7.5	74.2	299.7
11	N	1.5	F		21	75178085044090848	16,021.9520	7.5	74.2	299.7
12	N	1.5	F		23	75178085044090848	16,021.9520	7.5	74.2	299.7
13	N	1.5	F		25	75178085044090848	16,021.9520	7.5	74.2	299.7
14	N	1.5	F		27	75178085044090848	16,021.9520	7.5	74.2	299.7
15	N	1.5	F		29	75178085044090848	16,021.9520	7.5	74.2	299.7
16	N	1.5	F		31	75178085044090848	1,033.4991	95.2	74.2	299.7
17	N	1.5	F		33	75178085044090848	271.9856	157.0		299.7
18	N	1.5	F		35	75178085044090848	131.1999	257.6		299.7
19	N	1.5	F		37	75178085044090848	79.1152	367.8		
20	N	1.5	F		39	75178085044090848	53.6683	457.9		
21	N	1.5	F		41	75178085044090848	39.1639	557.9		
22	N	1.5	F		43	75178085044090848	30.0382	657.8		
23	N	1.5	F		45	75178085044090848	23.8869	757.6		
24	N	1.5	F		47	75178085044090848	19.5239	857.3		
25	N	1.5	F		49	75178085044090848	15.3055	956.9		
26	N	1.5	F		51	75178085044090848	14.0546	1,062.7		
27	N	1.5	F		53	75178085044090848	12.3867	1,162.6		
28	N	1.5	F		55	75178085044090848	11.0289	1,262.4		
29	N	1.5	F		57	75178085044090848	9.9055	1,362.1		
30	N	1.5	F		59	75178085044090848	8.9633	1,461.8		

4.3-1

(mg/m³)

2

序号	风向	风速(m/s)	稳定度	面源的有效高度(m)	排气口处风速(m/s)	排气时间(min)	最大落地浓度(mg/m ³)	出现距离(m)	大气毒性重点浓度-1(m)	大气毒性重点浓度-2(m)
1	#	1.94	D	1.5	1.207325975939648	1	2.5954394	11.5	24.4	12.7
2	#	1.94	D	1.5	1.207325975939648	3	2.5954394	11.5	24.4	91.6
3	#	1.94	D	1.5	1.207325975939648	5	2.5954394	11.5	24.4	91.6
4	#	1.94	D	1.5	1.207325975939648	7	2.5954394	11.5	24.4	91.6
5	#	1.94	D	1.5	1.207325975939648	9	2.5954394	11.5	24.4	91.6
6	#	1.94	D	1.5	1.207325975939648	11	2.5954394	11.5	24.4	91.6
7	#	1.94	D	1.5	1.207325975939648	13	2.5954394	11.5	24.4	91.6
8	#	1.94	D	1.5	1.207325975939648	15	2.5954394	11.5	24.4	91.6
9	#	1.94	D	1.5	1.207325975939648	17	2.5954394	11.5	24.4	91.6
10	#	1.94	D	1.5	1.207325975939648	19	2.5954394	11.5	24.4	91.6
11	#	1.94	D	1.5	1.207325975939648	21	2.5954394	11.5	24.4	91.6
12	#	1.94	D	1.5	1.207325975939648	23	2.5954394	11.5	24.4	91.6
13	#	1.94	D	1.5	1.207325975939648	25	2.5954394	11.5	24.4	91.6
14	#	1.94	D	1.5	1.207325975939648	27	2.5954394	11.5	24.4	91.6
15	#	1.94	D	1.5	1.207325975939648	29	2.5954394	11.5	24.4	91.6
16	#	1.94	D	1.5	1.207325975939648	31	91.4509	92.7		
17	#	1.94	D	1.5	1.207325975939648	33	16.2149	260.7		
18	#	1.94	D	1.5	1.207325975939648	35	6.0011	428.2		
19	#	1.94	D	1.5	1.207325975939648	37	3.7801	595.6		
20	#	1.94	D	1.5	1.207325975939648	39	2.4349	762.0		
21	#	1.94	D	1.5	1.207325975939648	41	1.7069	929.0		
22	#	1.94	D	1.5	1.207325975939648	43	1.2741	1,099.7		
23	#	1.94	D	1.5	1.207325975939648	45	0.9839	1,266.6		
24	#	1.94	D	1.5	1.207325975939648	47	0.7995	1,433.4		
25	#	1.94	D	1.5	1.207325975939648	49	0.6586	1,600.1		
26	#	1.94	D	1.5	1.207325975939648	51	0.5531	1,766.6		
27	#	1.94	D	1.5	1.207325975939648	53	0.4719	1,933.1		
28	#	1.94	D	1.5	1.207325975939648	55	0.4077	2,099.4		
29	#	1.94	D	1.5	1.207325975939648	57	0.3563	2,265.7		
30	#	1.94	D	1.5	1.207325975939648	59	0.3144	2,431.9		

4.3-2

(mg/m³)

-1 770mg/m³

74.2m

2min

-2 110mg/m³

299.7m

8min

4.3.5

30

1

20%

20%

10min

HJ 169-2018

A

Q_L

$$Q_L = C_d A \rho \sqrt{\frac{2(P - P_0)}{\rho} + 2gh}$$

Q_L kg/s

C_d 0.6-0.64

A m^2

ρ kg/m^3

P_0 P Pa

g $9.8m/s^2$

h m

2

4.3-12

4.3-12

	mm	m²		m	kg/m³	Pa	Pa
	10	0.00008	0.62	3.5	1460	101325	101325

0.59kg/s

354kg

4.3.6

100%

HJ169-2018

F

$$Q_L = C_d A \rho \sqrt{\frac{2(P - P_0)}{\rho} + 2gh}$$

Q kg/s

Cd

A m²

P Pa

kg/m³

P0 Pa

g 9.81m/s²

h m

EIAProA2018

F 1atm

25 1m 1830kg/m³

10mm 100%

A=0.0052 3.14=7.85 10⁻⁵m² 30min

0.93kg/s 30min 1680.8kg

4.3.7

4.3.8

4.3.9

()

CO

SO₂ NO_x

4.3.10

4.3.11

5						
6						

7

VOCs

10						

5

5.1

5.1.3

3		
4		

5

5.4

		PH	SS
			TRT
	1 2	DCS	
	1 2	/	/

5.5

5.5.1

5.5.2

5.5-1

		GB30077-2023
		/
		/
		/

5.6

5.6-1

1		
2		
3	4#	1
4	4#	
5		

6		
7	GB30077-2023	
8		

3

3-6

6

6

6.1

6.1-1

6.1-1

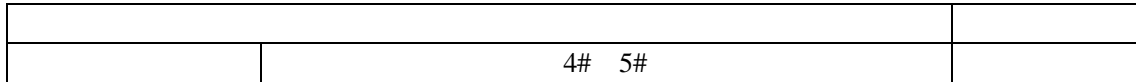

7

7.1

HJ941-2018

M Q
E

7.2

7.2.1

Q

A

NH₃-N

/---j d,I

COD_{Cr}

.-----j d,I

A

Q

1

Q

2

Q

$$Q = \frac{w_1}{W_2} + \frac{w_2}{W_2} + \dots + \frac{w_n}{Wn}$$

w1 w2 ...Wn

t

W1 W2 ...Wn

t

Q 1 Q0

. N 10 Q1

. - N 100 Q2

N . - - Q3

7.2-1

		t	t		Q	Q
		4.89	10		0.489	43.54
		0.2	10		0.02	
		396.4	10		39.64	
		33.29	10		3.329	
		0.3	10		0.03	
		0.1	10		0.01	
		48.2	2500		0.019	

Q 43.54 10 N 100 Q2

7.2.2

M

M

30

7.2-2

	10/		0
a	5/	2 5	30

	b	5/		0
	/	0	/	0
a	0--		p .-+J M	
	GB30000.2	GB30000.13	b	
			/	30

7.2-3

70

7.2-3

	1 A			
	2	0		25
		25		
		0		0
		25		
3		20		0
		15		
		10		
		0		
				25

7.2-4

4

7.2-4

	M	
M 25		M1
/ J 45		M2
1 J 65		M3
J		M4

7.2-3

55

7.2-4

M

M3

7.2.3

E

5	500					1
2	3	E1	E2	E3	7.1-5	
			1	2	3	

7.2-5

1 E1	5			5		500
	1000		5			
2 E2	5			1	5	
	500	500	1000			
3 E3	5			1		500
	500					

5

77688

E1

7.2.4

E

Q

M

7.2-6

7.2-6

E	Q	M			
		M1	M2	M3	M4
1 E1	. N 10 Q1				
	.- N 100 Q2				
	N .-- Q3				
2 E2	. N 10 Q1				
	.- N 100 Q2				

	N .-- Q3				
E3	. N 10 Q1				
	.- N 100 Q2				
	N .-- Q3				

- Q2-M3-E1

7.3

7.3.1

Q

A

Q

7.3-1

		t	t		Q	Q
		396.4	10		39.64	43.8
		33.29	10		3.329	
		81.2	100		0.812	
		48.2	2500		0.019	

Q 43.8 10 N 100 Q2

7.3.2

M

M

30

7.3-2

	10/		0
a	5/	2	5 30
b	5/		0
/	0	/	0
a	0-- GB30000.2	p . - +J M b	
			30

7.3-3

70

7.3-3

	1		
	2		
	3	0	0

		8	
	1		0
	2	0	
	3		
		8	

1
2

M

M2

7.3.3

E

1 2 3

E1 E2 E3

7.3-5

1 2 3

7.3-5

1 E1	1		10
	2	24	
2 E2	1		10
	2		10
	3		
3 E3		1 2	

E3

7.3.4

E

Q

M

7.2-6

- Q2-M2-E3

7.4

7.4.1

7.4.2

7.4.3

7.2.4

7.3.4

Z [+
Q2-M2-E3] [- Q2-M3-E1 + -

8.

6-1

9

1

2

3

4

5

6

7

8

9

10

11

12

1

2

3 5km

4

5

6

7 10km

8

9

10

11